

NOTE: This disposition is nonprecedential.

**United States Court of Appeals
for the Federal Circuit**

**PHILIPS LIGHTING NORTH AMERICA CORP.,
PHILIPS LIGHTING HOLDING B.V.,**
Appellants

v.

**WANGS ALLIANCE CORPORATION, DBA WAC
LIGHTING CO.,**
Appellee

2017-1526

Appeal from the United States Patent and Trademark
Office, Patent Trial and Appeal Board in No. IPR2015-
01287.

Decided: April 18, 2018

ROBERT MANHAS, Wilmer Cutler Pickering Hale and
Dorr LLP, Washington, DC, argued for appellants. Also
represented by ARIANNA EVERS; MARK CHRISTOPHER
FLEMING, CYNTHIA D. VREELAND, Boston, MA.

DAVID C. RADULESCU, Radulescu LLP, New York, NY,
argued for appellee. Also represented by ETAI LAHAV,
MICHAEL D. SADOWITZ, TIGRAN VARDANIAN.

Before MOORE, TARANTO, and CHEN, *Circuit Judges*.

TARANTO, *Circuit Judge*.

Philips Lighting North America Corp. owns U.S. Patent No. 6,013,988. In an inter partes review, the Patent Trial & Appeal Board decided that claims 1 and 2 of the patent are unpatentable. We affirm.

I

A

The '988 patent describes a circuit arrangement for a signaling light, such as a traffic light, that uses a light-emitting diode (LED), rather than a traditional incandescent lamp, as its light source. '988 patent, col. 1, lines 21–31. Typically, a signaling light in a traffic light system is regulated by a control unit having a solid-state relay—an electronic switch that turns on and off the power supplied to the light. *Id.*, col. 1, lines 32–34; *see also id.*, col. 3, lines 21–25. The control unit conducts status tests of the relay and of the signaling light at the connection terminals to make sure that multiple traffic lights (*e.g.*, red and green) are not on at the same time. *See id.*, col. 1, lines 32–41.

Although replacing traditional incandescent traffic lights with LEDs saves energy, a simple replacement causes problems for the status tests. *Id.*, col. 1, lines 38–41. The problem derives from the fact that solid-state relays conduct current even in the “off” state, resulting in “leakage current.” *Id.*, col. 1, line 36–38. “Leakage current” is not a problem for an incandescent lamp, which has “a comparatively low impedance . . . in the extinguished state, with the result that the removal of the leakage current through the incandescent lamp leads to only a low voltage at the connection terminals of the control circuit.” *Id.*, col. 1, lines 61–65. But leakage current is a problem for LEDs, which are semiconductor

light sources having a high impedance even in the “off” state; for LEDs, leakage current from a solid-state relay results in a relatively high voltage at the connection terminals and produces incorrect status test results. *Id.*, col. 1, lines 36–41.

The solution described in the ’988 patent is the addition of a subsidiary circuit called a “self-regulating current-conducting network,” which allows for the retrofitting of LEDs in existing traffic light systems without producing status-test problems. *Id.*, col. 1, lines 47–59. An LED traffic light system is depicted in Figure 1 of the patent (Philips-annotated version below), where VB is the control unit; LB is the LED; A and B are the connection terminals to the control unit; and C and D are the connection terminals to the LED. *Id.*, col. 2, lines 55–60, & Fig. 1.

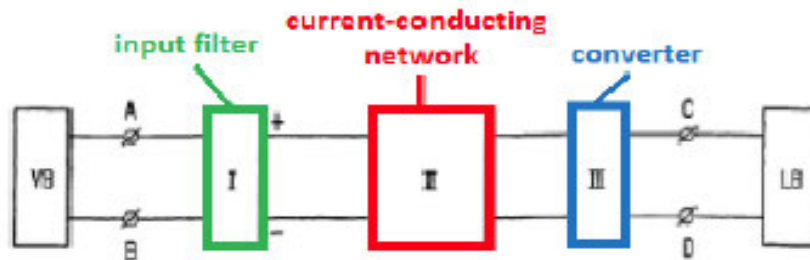

This case has focused on the three numbered components (I, II, and III) and the order in which they appear: specifically, I before II before III. The input filter (I) selectively rejects and transmits input signals at particular frequencies and contains a rectifier that transforms alternating current (AC) from the power lines to direct current (DC) that flows to the LED. *Id.*, col. 2, lines 22–24, 57; *id.*, col. 4, lines 2–5; see also *Wangs Alliance Corp. v. Koninklijke Philips N.V.*, No. IPR2015-01287, 2015 WL 9599171, at *4 (P.T.A.B. Nov. 30, 2015) (*Institution Decision*). The converter (III) contains a control circuit and a switch-mode converter (“switching element”) that oper-

ates the LED. '988 patent, col. 2, lines 15–22, 57–58; *id.*, col. 4, lines 24–60 & Fig. 4 (control circuit = SC). Between the filter and converter, *i.e.*, after filter I and before converter III, a “self-regulating current-conducting network” (II) drains off the leakage current from the control unit VB when the control unit is in the “off” state, resulting in a low voltage at the connection terminals and therefore producing correct status test results. *Id.*, col. 1, lines 47–55; *id.*, col. 2, lines 59–60.

That configuration is described in independent claim 1 of the patent, which reads:

1. A circuit arrangement for operating a semiconductor light source, said circuit arrangement comprising:

connection terminals for connecting the circuit arrangement to outputs from a control unit for controlling the semiconductor light source;

input filter means coupled to the connection terminals;

a converter comprising a control circuit, said converter being coupled to output means of the input filter means; and

output terminals for coupled to output means of said converter for connecting said circuit arrangement to the semiconductor light source,

characterized in that said converter comprises a switched-mode power supply for providing power to said semiconductor light source, said switched-mode power supply having a switching element which is cyclically switched on and off by said control circuit, and the circuit arrangement further comprises ***a self-regulating current-conducting network coupled between said filter means and said converter***, said self-

regulating current-conducting network draining off a leakage current in the control unit when said control unit is in a non-conducting state.

Id., col. 5, lines 9–32 (emphasis added).

Dependent claim 2 covers a preferred embodiment, in which the circuit arrangement includes a means for deactivating the current-conducting network when the control unit is in the “on” state so that there is no power dissipation through the current-conducting network. *Id.*, col. 1, line 66 through col. 2, line 3. Claim 2 reads: “The circuit arrangement as claimed in claim 1, characterized in that the circuit arrangement comprises means [f]or deactivating the self-regulating current-conducting network [w]hen the converter is switched on.” *Id.*, col. 5, lines 33–36. The deactivating means in that preferred embodiment may be separate from the other components in Figure 1 or may, in a further preferred embodiment, form part of the control circuit of the converter III. *Id.*, col. 3, lines 33–60 & Figs. 2–3.

B

Wangs Alliance Corporation filed a petition for an inter partes review of the ’988 patent under 35 U.S.C. §§ 311–19. The Board instituted a review of claims 1 and 2 as likely unpatentable for obviousness under 35 U.S.C. § 103 based on the combination of U.S. Patent No. 5,661,645 (Hochstein) and U.S. Patent No. 5,075,601 (Hildebrand). *Institution Decision*, 2015 WL 9599171, at *9. The Board issued a final written decision on November 23, 2016, concluding that both claims 1 and 2 are unpatentable for obviousness based on the Hochstein/Hildebrand combination. J.A. 1–55 (Final Written Decision, *Wangs Alliance Corp. v. Koninklijke Philips N.V.*, No. IPR2015-01287 (P.T.A.B. Nov. 23, 2016), Paper No. 60 (*Board Decision*)).

Philips timely appealed that decision. We have jurisdiction under 28 U.S.C. § 1295(a)(4)(A).

II

Philips challenges, for lack of substantial evidence support, the Board’s factual findings that a skilled artisan would have been motivated to combine Hochstein and Hildebrand and had a reasonable expectation of success based on that combination. *See Novartis AG v. Torrent Pharms. Ltd.*, 853 F.3d 1316, 1324 (Fed. Cir. 2017). We reject both challenges.

A

Substantial evidence supports the Board’s determination that a person of ordinary skill in the art would have been motivated to combine Hochstein and Hildebrand. Hochstein specifically addresses the leakage current problem caused by using LEDs in traditional traffic signal lights, and it proposes a solution that drains leakage current without causing inefficient use of electric power (poor power factor). Hochstein, col. 5, lines 11–26; *id.*, col. 6, lines 31–62. Hochstein’s Figure 5, reproduced in the Board’s decision with annotations by Philips, shows the (now undisputed) correspondence to the ’988 patent elements at issue:

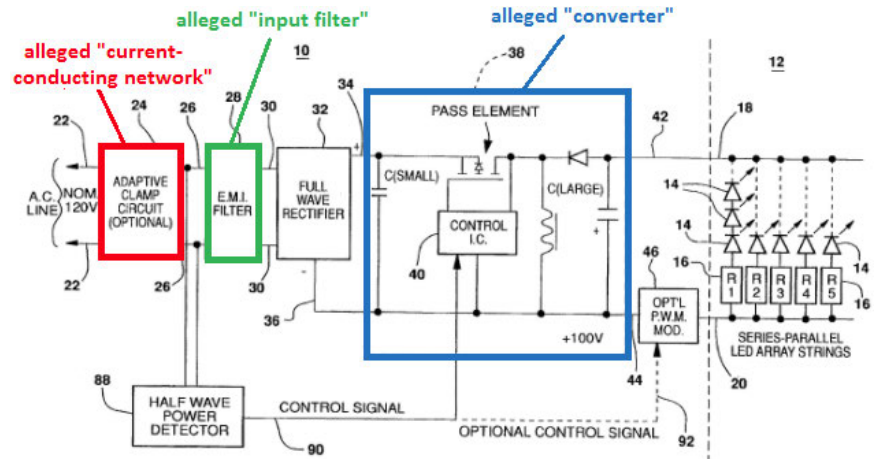

Board Decision at 27.

As seen in the figure, an optional adaptive clamp circuit, corresponding to the “current-conducting network” in the ’988 patent, is placed across the input terminals of the power lines. Hochstein, col. 7, lines 17–19. The location of the adaptive clamp circuit between the control unit and the LEDs allows the adaptive clamp circuit to monitor the line voltage and switch itself in or out of the circuit as necessary. *Id.*, col. 7, lines 39–50. Meanwhile, the input filter component “keeps conducted interference from feeding back into the power lines where it might cause problems to other circuitry on the line.” *Id.*, col. 5, lines 33–35. In the configuration in Hochstein, the adaptive clamp circuit is before the filter, not “between” the filter and the converter, as required by claim 1 of the ’988 patent. ’988 patent, col. 5, lines 27–29.¹ Hochstein gives no reason for placing the adaptive clamp circuit before, instead of after, the filter. *See Board Decision* at 44.

Hildebrand shows a traffic light system with an order of pertinent components that matches the order in the ’988 patent, though not in the LED context. Like Hochstein and the ’988 patent, Hildebrand recognizes the leakage current and status test problem; but Hildebrand discusses that problem in the context of replacing traditional incandescent lamps with neon or fluorescent traffic lights, not LEDs. Hildebrand, col. 1, lines 11–33. Hildebrand proposes using a “dynamic load” circuit (corresponding to the ’988 patent’s “current-conducting network”) to drain the excess current at low voltages. *Id.*, col. 1, lines 34–41. Hildebrand places the “dynamic load” circuit after the input filter, *i.e.*, as in the ’988 patent, “between” the filter and the converter. *Board Decision*

¹ We focus on claim 1, as Philips makes no separate arguments on appeal as to dependent claim 2.

at 31; *see* Hildebrand, col. 5, line 57 through col. 6, line 6 & Fig. 1A.

On appeal, Philips does not dispute the Board’s finding that the invention in claim 1 of the ’988 patent is disclosed by the combination of Hochstein and Hildebrand—*i.e.*, by using Hochstein’s group of components, including an LED, but with Hildebrand’s sequencing (current-conducting network *after* the input filter). Philips argues, however, that the Board improperly failed to identify an “affirmative reason” to combine Hochstein and Hildebrand and instead relied solely on the notion that choosing the order of components was a matter of “design choice.” Philips’s Br. 23. We disagree with Philips’s reading of the Board decision, and we conclude that the Board’s rationale for the combination was sufficient under *KSR International Co. v. Teleflex Inc.*, 550 U.S. 398 (2007).

The Board did not rely on a broad notion of “design choice” as sufficient to find that a skilled artisan would have combined the references; to the contrary, it refused to adopt a “mere[] asserti[on]” of “design choice” and insisted on reviewing the context-specific evidence for the soundness of that rationale in the particular circumstances of this review. *Board Decision* at 36. The Board first found that both references address the same problem (*i.e.*, leakage current in traffic signal systems employing a light source different from traditional incandescent lamps) and propose similar solutions (*i.e.*, similar circuitry—adaptive clamp circuit in Hochstein, and dynamic load circuit in Hildebrand). *Id.* at 32–35. Both “references are thus substantially pertinent to solving precisely the same problem addressed by the ’988 patent and show the demand for designs that solve the known problem,” including the two in Hochstein and Hildebrand. *Id.* at 33.

The Board also made a specific finding that changing the order of the filter and adaptive clamp circuit (current-

conducting network analogue) in Hochstein was an obvious matter of design choice because the two designs were known in the art, recognized as solutions to the particular problem, and functionally equivalent. *Id.* at 36–45. The Board determined that a person of skill in the art would look to both Hochstein and Hildebrand to solve the leakage current problem and that those two references “disclose the two possible locations for the circuitry that drains the leakage current: either before an input filter or after an input filter.” *Id.* at 38. The Board further found that Hochstein nowhere teaches that the filter’s function includes protection of the adaptive clamp circuit from converter-generated noise or precludes placement of the filter before the adaptive clamp circuit (the location in Hildebrand and the ’988 patent). *Id.* at 43–44.

For further support, the Board pointed to an excerpt from the textbook *Fundamentals of Power Electronics*, which states that “[i]t is nearly always required that a filter be added at the power input of a switching converter.” *Id.* at 43 (quoting Robert W. Erickson, *Fundamentals of Power Electronics* 377 (2d ed. 2001)).² Based on that excerpt, the Board found that a person of ordinary skill would understand not only the operation of that filter but also that the “fundamental placement” of the filter is at the power input. *Id.* at 44.

Based on the teachings of Hildebrand and Hochstein and the testimony of Wangs’s expert Mr. Robert Tingler, with support from *Fundamentals of Power*, the Board found that a person of skill, reading Hochstein, would know that the input filter may be placed at the power

² Philips argues in its reply brief in this court that the Board was not entitled to rely on this particular excerpt from *Fundamentals of Power*. Philips’s Reply Br. 18–22. But Philips did not so argue in its principal brief. We therefore do not consider the argument.

input *before* the adaptive clamp circuit, as shown in Fig. 1A in Hildebrand and in Figure 1 of the '988 patent. *Id.* at 41–45; *see also id.* at 37 (“The various differences between Hochstein and Hildebrand have not been shown to be of particular relevance to selecting whether to place the adaptive clamp circuit after the [input] filter.”).

The Board considered, but rejected, Philips’s argument that a skilled artisan would not place Hochstein’s input filter before the adaptive clamp circuit because that modified configuration would expose the adaptive clamp circuit to malfunctioning noise from the converter. *See id.* at 43 (noting that Philips’s expert Dr. Regan Zane testified in his deposition that a skilled artisan would not know how to address any noise issues and speculated that such noise “could cause undesirable behavior,” but not testifying as to what level of noise would be generated by the converter or its result) (quoting J.A. 1246–47). The Board was persuaded by the record evidence, including the testimony of Wangs’s expert Mr. Tingler, that, even if the adaptive clamp would be exposed to noise from the converter, the noise from the converter would not be a “malfunctioning” noise that would counsel against the adoption of a filter-first configuration by a relevant skilled artisan, who would be able to identify and mitigate any noise. *Id.* at 42–43.³ The Board ultimately found “that it is highly unlikely that [the] adaptive clamp circuit would be affected by noise, and thus malfunction.” *Id.* at 45.

Philips complains that the Board did not identify the specific “affirmative reason” for a person of skill looking at Hochstein to adopt the alternative configuration in Hildebrand. But in the circumstances of this case, we conclude, Philips is demanding too much. Under *KSR*, we see no need for more than what the Board found in this case,

³ In section II.B *infra*, we discuss this expert dispute about noise malfunction further.

including that (1) there were just two obvious design choices in the respect put at issue (Hochstein and Hildebrand), which solve the same problem in the same way but with the filter and current-conducting network swapped in their locations, (2) the two references “show the demand for designs that solve the known problem,” *id.* at 33; (3) Hildebrand’s location choice was a common and approved design that could be used in Hochstein; and (4) Hochstein would not malfunction if modified to use such a design. These findings suffice to establish a reason for a skilled artisan, seeking to solve the status-test problem, to use a three-component circuit arrangement as found in both references and to choose either of the two disclosed orders of the first two components within that arrangement—specifically, the order that is especially common in the art and that is used in the ’988 patent. *See KSR*, 550 U.S. at 416 (combining “familiar elements according to known methods is likely to be obvious when it does no more than yield predictable results”).

For those reasons, we conclude that substantial evidence supports the Board’s finding of a motivation to combine.⁴

B

Philips challenges the Board’s finding that a person of ordinary skill in the art would have had a reasonable expectation of success in changing the order of the filter and adaptive clamp in Hochstein. Philips contends that, unless the filter remained between Hochstein’s adaptive

⁴ Because we do not rely on the Board’s additional reasoning in a footnote of its decision that changing the order of Hochstein’s filter and adaptive clamp would provide an additional benefit, *Board Decision* at 44 n.12, we need not address Philips’s contention that Philips lacked adequate notice of that reasoning.

clamp and buck/boost converter, the converter would introduce noise that would cause the clamp to malfunction. The Board found that the relevant skilled artisan would have had a reasonable expectation of success because (1) the filter's original placement in Hochstein does not indicate a need to protect the adaptive clamp from noise; (2) any noise from the converter in the swapped configuration can be addressed by a person of skill; and (3) at the time when the adaptive clamp is most susceptible to malfunction, noise from the converter is at its lowest or nonexistent. *Board Decision* at 48 (referring to *id.* at 41–45). We conclude that the Board's finding is supported by substantial evidence.

First, Philips repeatedly characterizes Hochstein as teaching that its filter was intended to protect the *adaptive clamp* in addition to the AC grid, therefore preventing the proposed swap. But Hochstein does not say that, at least not clearly. Hochstein describes the filter as necessary to prevent “conducted interference from feeding back into the power lines where it might cause problems to other circuitry on the lines,” Hochstein, col. 5, lines 33–35, and states that “conducted interference is a concern because of the interference potential with other services (radio communications for example),” *id.*, col. 2, lines 60–63. Both parties' experts agreed on that point. And the Board found that Hochstein nowhere indicates that the filter must be placed between the converter and adaptive clamp to prevent noise from interfering with the functioning of the clamp. *Board Decision* at 44, 48.

Second, Philips argues that Mr. Tingler's testimony (for Wangs) is not sufficient to support the Board's finding that a person of skill could identify and mitigate any potential malfunction from any increased clamp exposure to converter-created noise caused by moving the filter to the pre-clamp position. We disagree. In response to Dr. Zane's testimony (for Philips) about possible malfunction, Mr. Tingler pointed out that Hochstein does not indicate a

concern for protecting the adaptive clamp circuit from noise. J.A. 1062.⁵ Even if it were a concern, Mr. Tingler added, a skilled artisan would build a prototype circuit in order to assess how the circuit functioned, including how much, if any, noise from the converter interfered with the adaptive clamp, and the skilled artisan could add “a tiny amount of filtering capacitance” between the converter and adaptive clamp if needed. J.A. 2948. On the record developed in the proceeding, the Board could properly credit Mr. Tingler’s explanation.

It may be that Mr. Tingler was not very specific in his response to Dr. Zane’s malfunction theory—but neither was Dr. Zane very specific in explaining his theory. Dr. Zane’s theory was “that a person of ordinary skill in the art would not recognize what would be required to have a circuit that works properly in moving the adaptive clamp circuit from Hochstein to other locations.” *Board Decision* at 43. He observed that “[t]he adaptive clamp circuit [in Hochstein] would be largely protected from that [electromagnetic interference noise] sitting in its location on the AC line.” J.A. 1245. If moved to the Hildebrand location, Dr. Zane stated, the clamp “would be susceptible to any noise that feeds into that circuit, noise that could come from the power converter,” and such “noise on the line generated from the power converter could cause undesirable behavior of the circuit.” J.A. 1245–46. Dr. Zane did

⁵ As Wangs points out, the ’988 patent does not require a particular type of converter or explain how noise from any particular converter must be filtered in light of the location of the current-conducting network. *See* Wangs’s Br. 20 n.1 (citing ’988 patent, col. 2, lines 15–19). Although the current-conducting network in the ’988 patent has some internal filtering capacity, the disclosure does not indicate that such filtering is necessary for effective operation of the current-conducting network.

not identify how much noise is likely to be introduced by Hochstein’s buck/boost converter. Nevertheless, he contended that, if the noise occurs when the voltage level is near the threshold below which the adaptive clamp turns on to drain current, it could cause the adaptive clamp to turn on and off. See J.A. 1247–48 (adaptive clamp “changes its behavior” at particular “points . . . according to whatever the design is of that adaptive clamp circuit,” which “are the thresholds in the operation”); J.A. 1249 (“My opinion is that the noise that would be generated on the line could cause undesirable behavior of the circuit including, but not limited to, the turn on and off at these threshold points.”). Without any identification by Dr. Zane of a specific noise-level problem, the Board did not have to require Mr. Tingler to identify a solution more specific than he described.

Finally, Philips attacks the Board’s third finding, *i.e.*, that converter noise is at its lowest when the adaptive clamp is most susceptible to malfunction, as “unsupported and manifestly erroneous.” Philips’s Br. 37. But the Board’s finding of a reasonable expectation of success logically can stand on the Board’s first two findings, including the finding that a relevant skilled artisan could identify and mitigate any potential malfunction from relocating the filter; and Philips has not shown otherwise. In any event, this third finding was neither unsupported nor manifestly erroneous.

As Philips recognizes, Philips’s Br. 39 n.5, the Board’s finding was based on Mr. Tingler’s explanation that the adaptive clamp actively clamps (drains leakage current) only when the buck/boost converter is off and not generating noise. See *Board Decision* at 44 (citing J.A. 1063–64). Mr. Tingler reasoned that “because the adaptive clamp is not operating when the converter is on, and because the converter is the source of the [electromagnetic interference] noise, it is highly unlikely that the adaptive clamp circuit could be affected by such noise.” J.A. 1064. Based

on that testimony, the Board “deduce[d] that, when the converter is off, any noise from the converter is at its lowest or absent when the adaptive clamp circuit is supposed to sense the threshold voltage in order to drain the current.” *Board Decision* at 44.

In making that finding, the Board properly focused on the source of the potential “malfunction” suggested by Philips’s expert—noise generated when the voltage is at a level near the clamp’s on/off threshold for its draining operation (*e.g.*, 40 volts, *see* Hochstein, col. 6, lines 42–45; *id.*, col. 7, lines 53–57), causing the clamp mistakenly to switch to or from the draining position. *See* J.A. 1245–49 (Zane deposition testimony). And the Board had a sufficient basis, in Mr. Tingler’s testimony and Hochstein, to find that such a mistake is unlikely to occur when the converter is making noise of any significance. The Board could find that such noise occurs only when the converter is on. When the converter is on, however, although there may be noise, it is highly unlikely to matter for the clamp’s on/off decision. That is because the clamp bases that decision on voltage being below an on/off threshold that is far lower than the voltage present when the converter is on. *See* Hochstein, col. 6, lines 36–45 (“The adaptive clamp circuit monitors the input voltage feeding the LED array” and “assumes that voltages lower than a certain value (typically 40 volts) are due to leakage currents through the solid state control relay or switch.”); *id.*, col. 7, line 63 to col. 8, line 1 (voltage of 120V applied when light turns on); J.A. 1064 (120V applied when light, hence converter, is on). On the evidence, it is reasonable to find that any noise from the converter is unlikely to cause the clamp to somehow sense, at the already high level of voltage, a much lower level of voltage at which the clamp makes its on/off decision.

For those reasons, we see no reversible error in the Board’s determination that a person of skill would have

had a reasonable expectation of success based on the proposed combination.

III

We affirm the Board's ruling that claims 1 and 2 of the '988 patent are unpatentable.

Each party shall bear its own costs.

AFFIRMED